

Mercury™-Atlas

"The conquest of space is such a fantastic, gorgeous and colossal subject, that it's hard to know where to begin."

James S. McDonnell, 1959
 President, McDonnell™ Aircraft Corporation

In 1959, the race between the United States and the Soviet Union to conquer space was heating up, and NASA awarded the contract to the McDonnell™ Aircraft Corporation to build the Mercury™ capsule – the spacecraft that would fly the first American Astronauts into space. After an exhaustive test program, and under pressure to beat the Soviets, the Mercury™ spacecraft flew its first orbital flights on the Convair Atlas SLV-3D booster, a derivative of the successful SM-65D Atlas missile. Four brave American Astronauts flew these dangerous missions, where the temperatures outside their spacecraft reached over 1,000 degrees Celsius upon re-entry. The Mercury™ missions were a success proving that man could travel safely into space, paving the way for more ambitious programs that included landing on the moon.

Specifications: Mercury™-Atlas SLV-3D

Length: 96.9 feet (29.5 metres) with Mercury™ Capsule
 81.9 feet (25.0 metres) with Mercury™ Boilerplate
 Diameter: 10 feet (3.05 metres)
 Weight: over 260,000 lbs (118,000 kg)
 Engines: Two LR-89 boosters with 150Klbs thrust each
 One LR-105 sustainer with 57Klbs thrust
 Two LR-101 verniers with 1Klbs thrust each



Mission Summary

All missions were launched from Cape Canaveral Launch Complex 14

Mission	Capsule	Atlas	Launch Date	Orbits	Duration	Astronaut	Call sign
Big Joe	Boilerplate	10D	Sep 09, 1959	0	0:13:00	*	*
MA-1	Porthole	50D	Jul 29, 1960	0	0:03:18	*	*
MA-2	Porthole	67D	Feb 21, 1961	0	0:17:56	*	*
MA-3	Porthole	100D	Apr 25, 1961	0	0:07:19	*	*
MA-4	Porthole	88D	Sep 13, 1961	1	1:49:20	*	*
MA-5	Window	93D	Nov 29, 1961	2	3:20:59	Enos the Chimp	*
MA-6	Window	109D	Feb 20, 1962	3	4:55:23	John H. Glenn, Jr.	<i>Friendship 7</i>
MA-7	Window	107D	May 24, 1962	3	4:56:05	M. Scott Carpenter	<i>Aurora 7</i>
MA-8	Window	113D	Oct 03, 1962	6	9:13:15	Walter M. Shirra, Jr.	<i>Sigma 7</i>
MA-9	Window	130D	May 15, 1963	22	34:19:49	L. Gordon Cooper, Jr.	<i>Faith 7</i>



LOCKHEED MARTIN®, CONVAIR®, ATLAS®, associated emblems and logos, and body designs of vehicles are either registered trademarks or trademarks of Lockheed Martin Corporation in the USA and/or other jurisdictions, used under license by Horizon Models Pty Ltd.

Produced under license. Boeing, McDonnell, Mercury, their distinctive logos, product markings and trade dress are trademarks of The Boeing Company.

⚠ WARNING

CHOKING HAZARD: KEEP AWAY FROM CHILDREN UNDER THREE YEARS OF AGE.

DO NOT USE PAINTS OR GLUES NEAR FLAMES OR FIRE, OR WITHOUT ADEQUATE VENTILATION.

This model is intended for ages 14 and older.

Beware of small and/or sharp parts.

Throw away plastic bags when no longer required.

PAINT AND GLUE NOT INCLUDED

Use paints and glues in a well ventilated area.

Take care when handling knives and other sharp objects.

Assembly

- 1 Study these instructions carefully before assembly and note the payload and marking options that you will build.
- 2 Remove the parts from the sprue one at a time with a sprue cutter, and carefully sand off any excess plastic.
- 3 Test fit the parts to ensure they fit correctly, then glue into place using polystyrene glue. When attaching PE parts, use a cyanoacrylate glue.
- 4 Some parts should be painted prior to gluing to the main assembly.
- 5 Before painting, carefully sand the model if required, then wash it in a soapy solution.
- 6 Allow to dry thoroughly before applying paint.
- 7 Paint the model in a well ventilated area, and allow to dry thoroughly.
- 8 Apply the decals (see instructions below).
- 9 Seal the decals with a clear coat of paint (allow at least one day for the decals to dry thoroughly).

Applying Decals

- 1 Cut the decal from the carrier sheet.
- 2 Dip the decal into water for about 10 seconds.
- 3 Place the decal on a cloth to absorb excess moisture.
- 4 Wet the model where you want to place the decal.
- 5 Slide the decal from the backing paper directly onto the model.
- 6 Do not lift the decal off the sheet as this may cause it to fold.
- 7 Once positioned correctly, press the decal gently with a soft cloth.

Horizon Models Pty Ltd
PO Box 305
Drummoyne NSW 2047
Australia

www.horizon-models.com

MADE IN AUSTRALIA

Sprue A (x2) Parts A7 & A11 not used

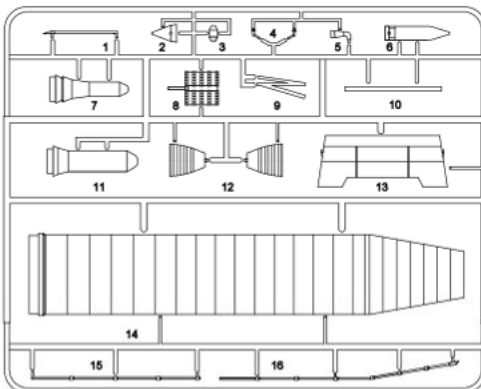

- 1 Fuel pressure line
- 2 Vernier fairing (small)
- 3 Cable way fairing cover
- 4 Vernier engine (x2)
- 5 Fuel fill & drain valve
- 6 Vernier fairing (large)
- 7 Mk 3 re-entry vehicle (not used)
- 8 Vernier heat radiation shield
- 9 Turbine exhaust duct brace
- 10 Cable way fairing (top)
- 11 Mk 4 re-entry vehicle (not used)
- 12 Booster engine half (x2)
- 13 Thrust structure fairing (lower)
- 14 Tank structure
- 15 Liquid oxygen pressure line (lower)
- 16 Liquid oxygen pressure line (upper)

Sprue B Part B9, B11 & B12 not used

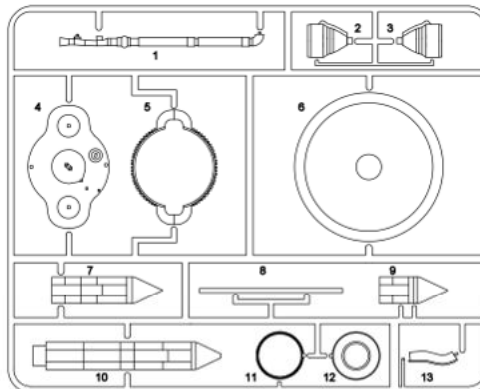

- 1 Liquid oxygen line
- 2 Sustainer engine (left half)
- 3 Sustainer engine (right half)
- 4 Fire shield nacelle
- 5 Thrust structure fairing (upper)
- 6 Display stand
- 7 Equipment pod (medium)
- 8 Cable way fairing (lower)
- 9 Equipment pod (not used)
- 10 Equipment pod (long)
- 11 Mk 2 re-entry vehicle (not used)
- 12 Nose cone adaptor (not used)
- 13 Booster engine turbine exhaust duct

Sprue M Parts M10, M11 & M14 not used

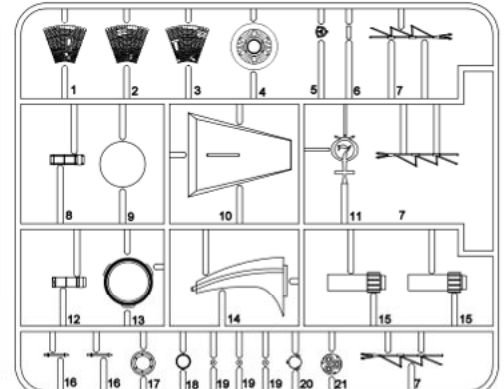

- 1 Capsule section 1
- 2 Capsule section 2
- 3 Capsule section 3
- 4 Boilerplate Capsule
- 5 Escape rocket base
- 6 Rocket adaptor part
- 7 Escape tower (x3)
- 8 Escape rocket
- 9 Capsule heat shield
- 10 Display stand (not used)
- 11 Mercury™ symbol (not used)
- 12 Escape rocket
- 13 Spaceraft adaptor
- 14 Display stand (not used)
- 15 Recovery compartment (x2)
- 16 Aerodynamic spike (x2)
- 17 Escape tower base
- 18 Antenna compartment
- 19 Escape tower rocket nozzle (x3)
- 20 Antenna compartment fairing
- 21 Retro-package

Photo Etched Parts (PE) Parts PE5 & PE6 not used

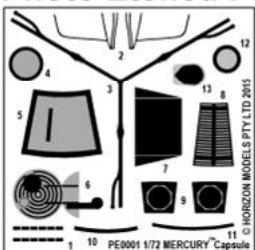

Use a cyanoacrylate glue to attach PE parts

- 1 Recovery compartment (x2)
- 2 Escape tower straps (x2)
- 3 Retopack restraining cord
- 4 LOX vent
- 5 Alternate hatch
- 6 Destabilizing flap (not used)
- 7 LOX vent cover
- 8 Capsule skin
- 9 Porthole window (x2)
- 10 Row of bolts (long)
- 11 Row of bolts (short)
- 12 Horizon sensor
- 13 Horizon sensor cover

© Horizon Models Pty Ltd 2015. All rights reserved.

A Flat Aluminium

C Exhaust Metal

E White

G Metallic Black/Blue

B Stainless Steel / Silver

D Red

F Black

H Titanium

1 AIRFRAME PREPARATION

Open holes as shown below

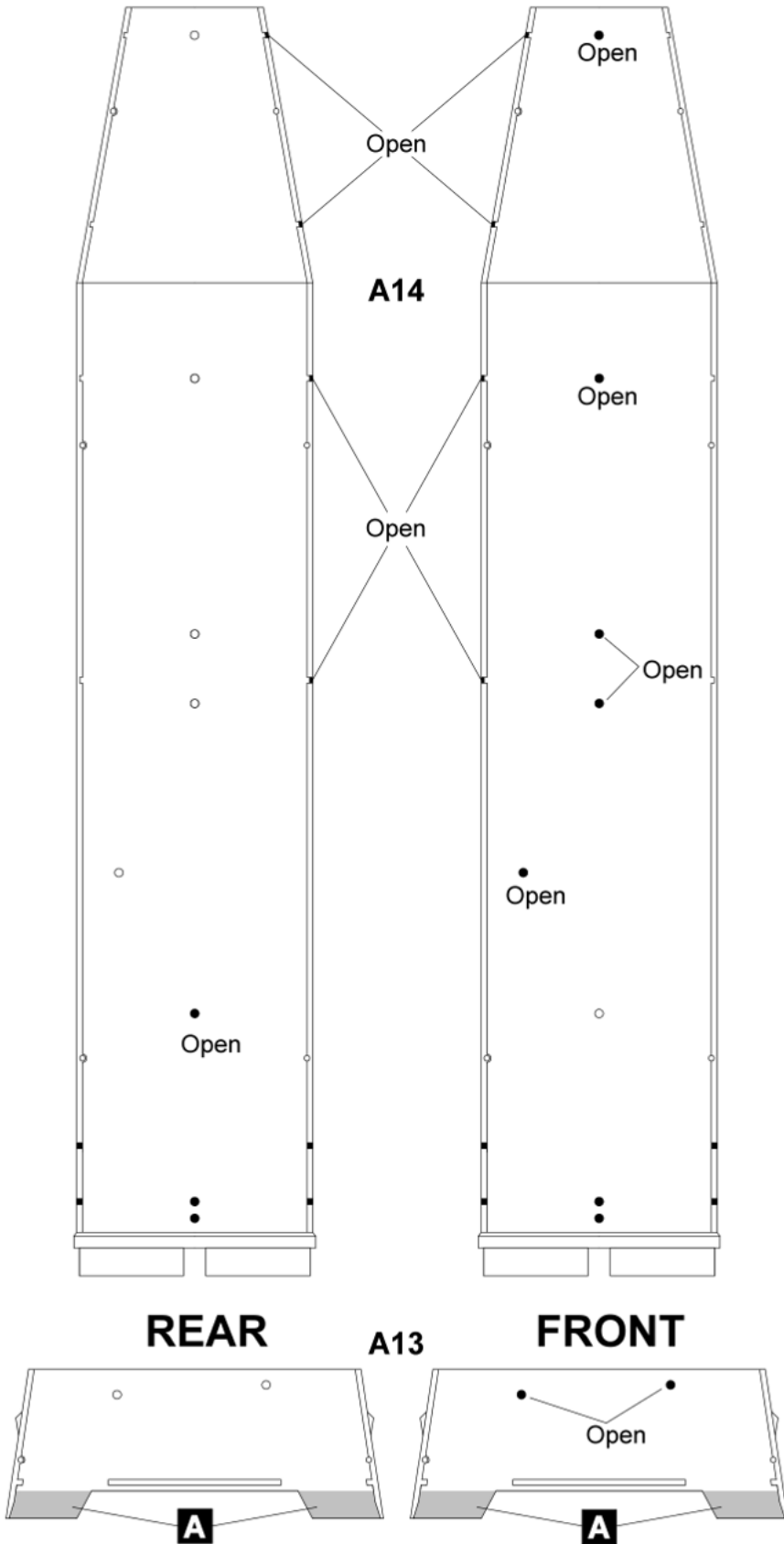

2 AIRFRAME ASSEMBLY

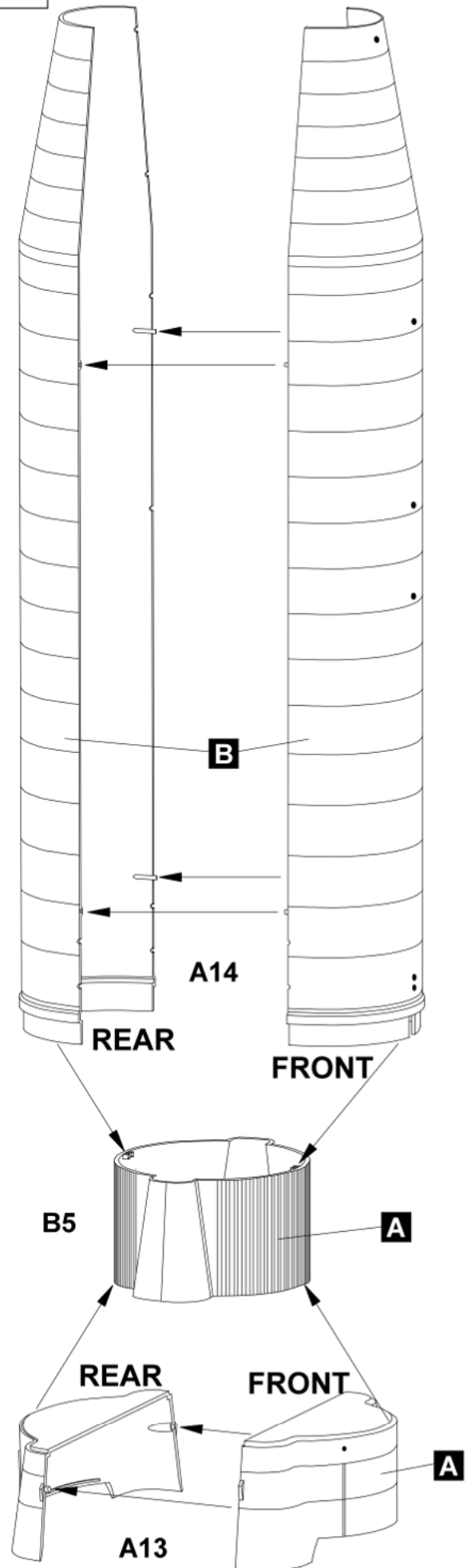

3

FRONT & REAR AIRFRAME ASSEMBLY

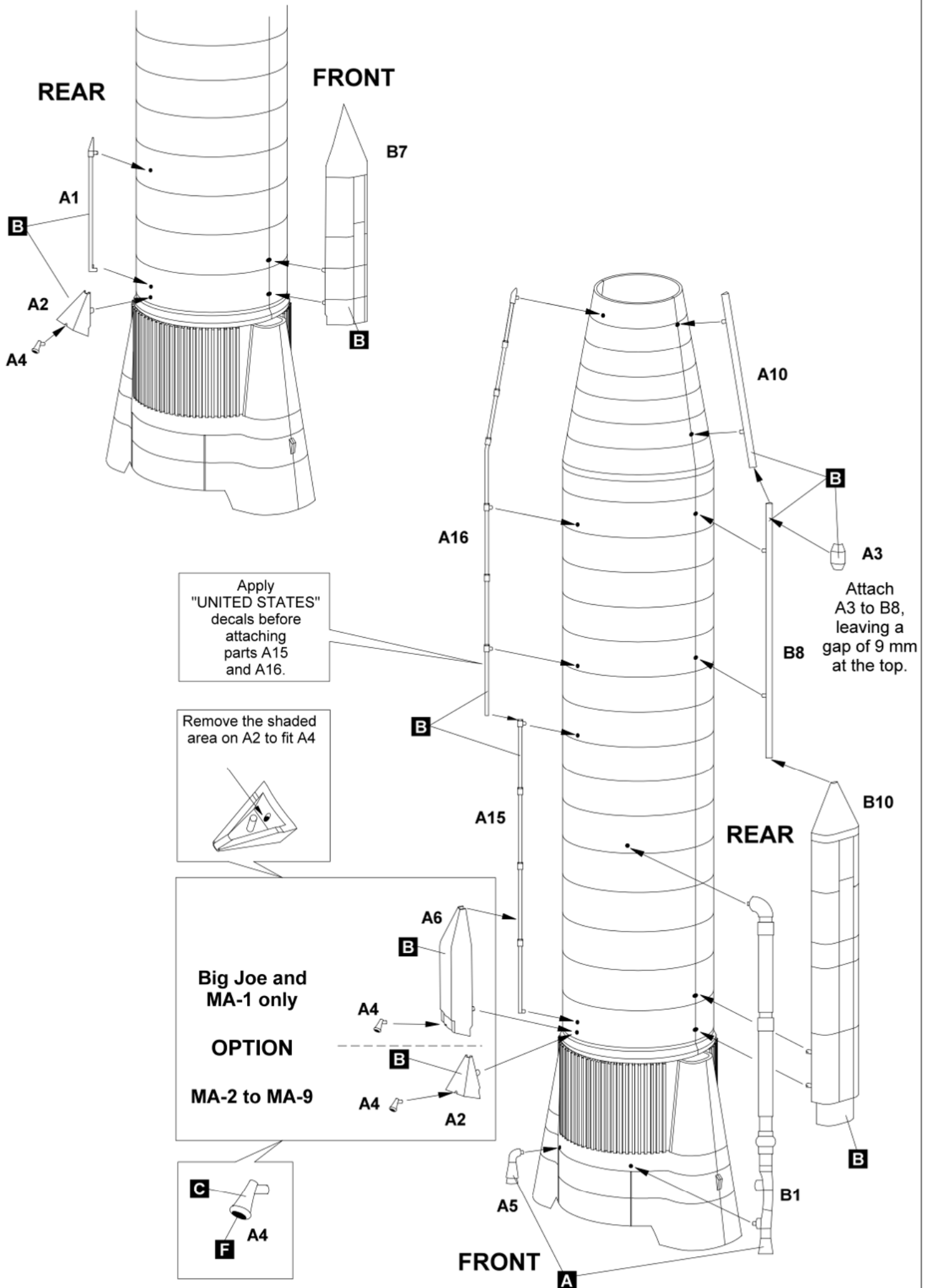

4 MERCURY™ CAPSULE

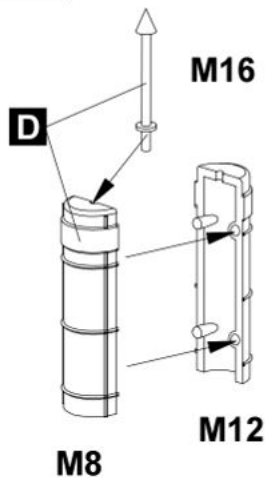

Line up the two ridges running along the length of part M8 with these two points.

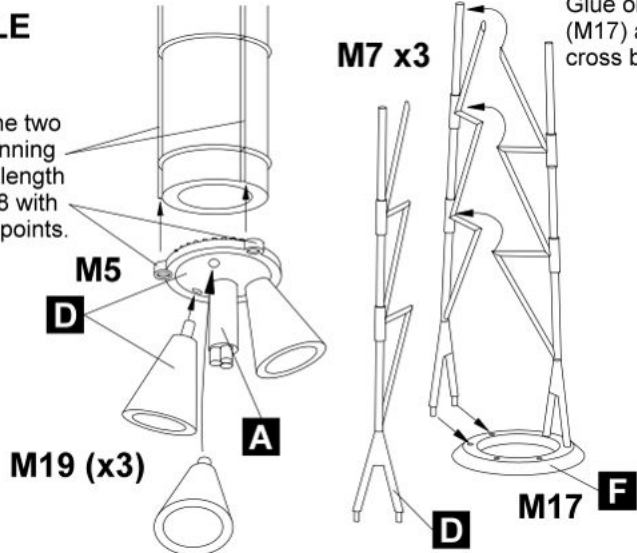

Glue one truss (M7) to the base (M17) at a time, then glue the cross beams to the other trusses.

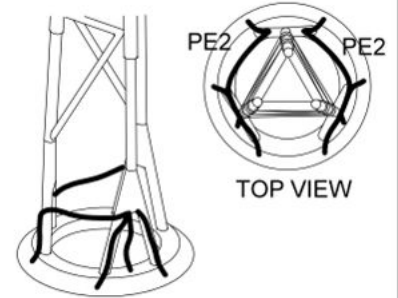

Attach PE2 (x 2) to two of the three trusses (M7) as shown. Connect the horizontal bars from each to the last truss, and then to the base M17.

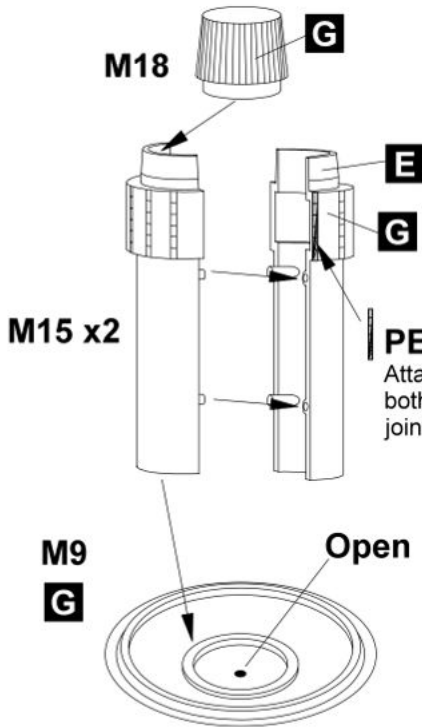

Attach PE1 to both sides along the join line of M15

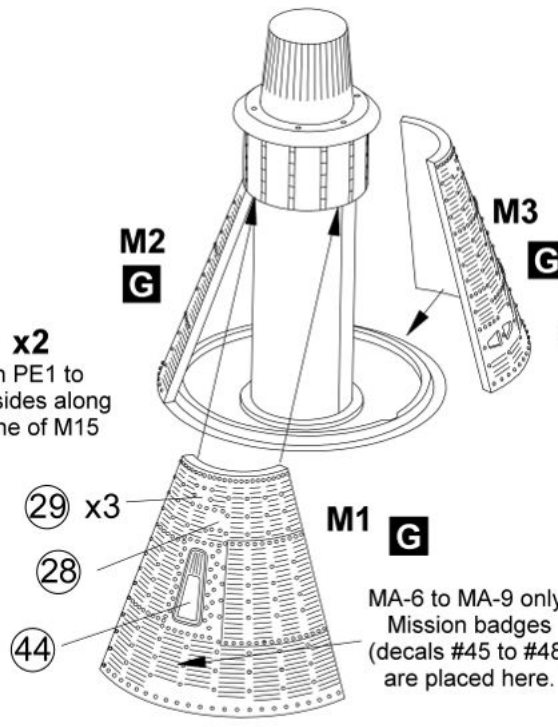

Line up the three tips of M20 with the inner walls of the tower.

PE2 omitted for clarity

Note - Parts M21 and PE9 will not be visible once the capsule is glued to the adaptor (M13). Paint part M21 before assembly. When dry, apply the decals as shown below. Then glue part PE3 to M21 and carefully attach to M9 as instructed below.

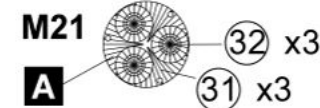
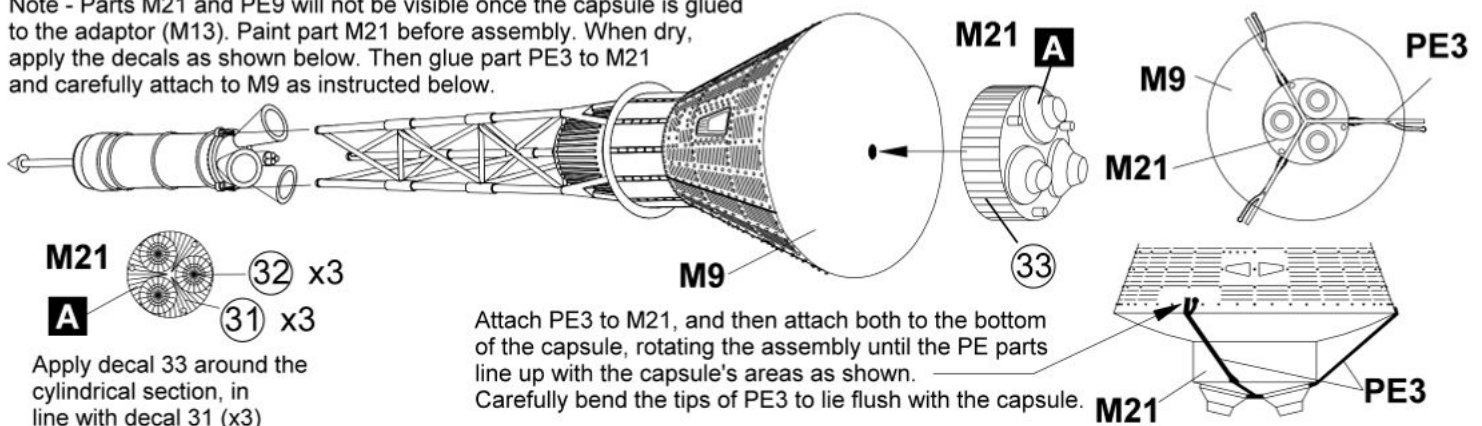

Apply decal 33 around the cylindrical section, in line with decal 31 (x3)

For MA-1 only, do not apply decals 31, 32 or 33.

Attach PE3 to M21, and then attach both to the bottom of the capsule, rotating the assembly until the PE parts line up with the capsule's areas as shown. Carefully bend the tips of PE3 to lie flush with the capsule.

Mercury™ Capsule: "Porthole" version Missions MA-1 to MA-4 only

Attach parts PE8 and PE9 (x2), PE10 and PE11 as shown to plastic parts M1, M2 & M3. Use a cyanoacrylate glue.

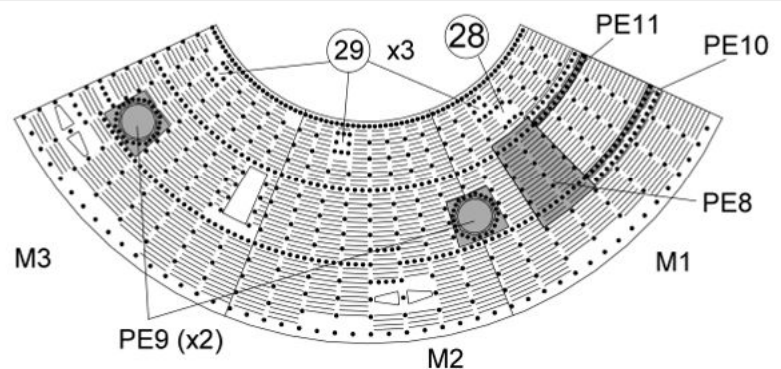

All parts

5 CAPSULE AND ADAPTOR ASSEMBLY

CHOOSE A PAYLOAD:
BOILERPLATE OR PRODUCTION CAPSULE

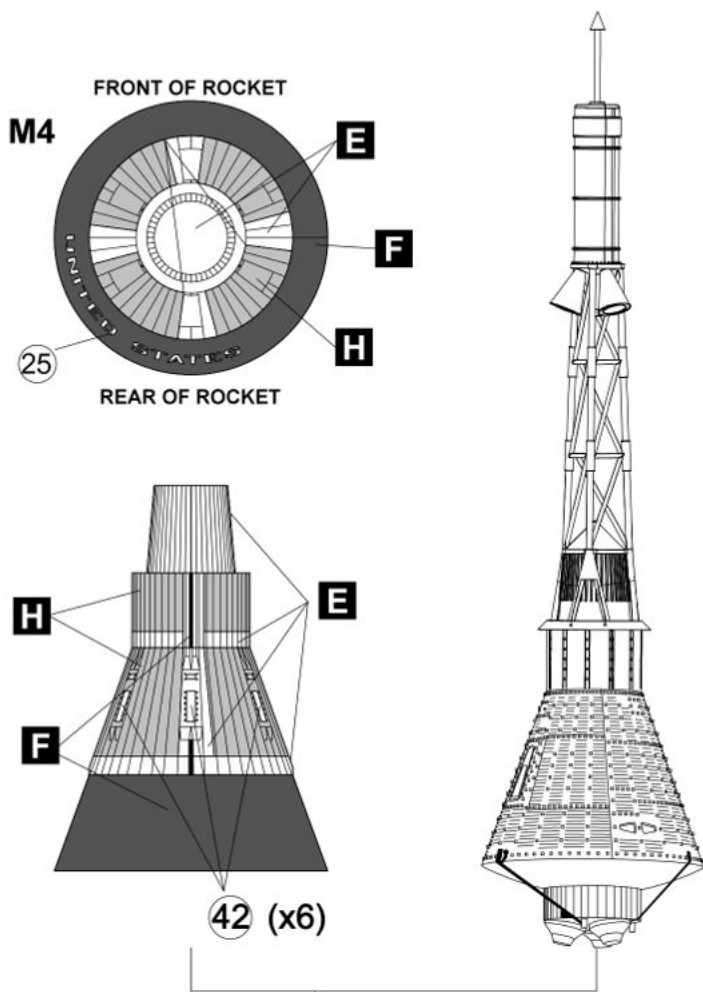

6 ROCKET ENGINE ASSEMBLY

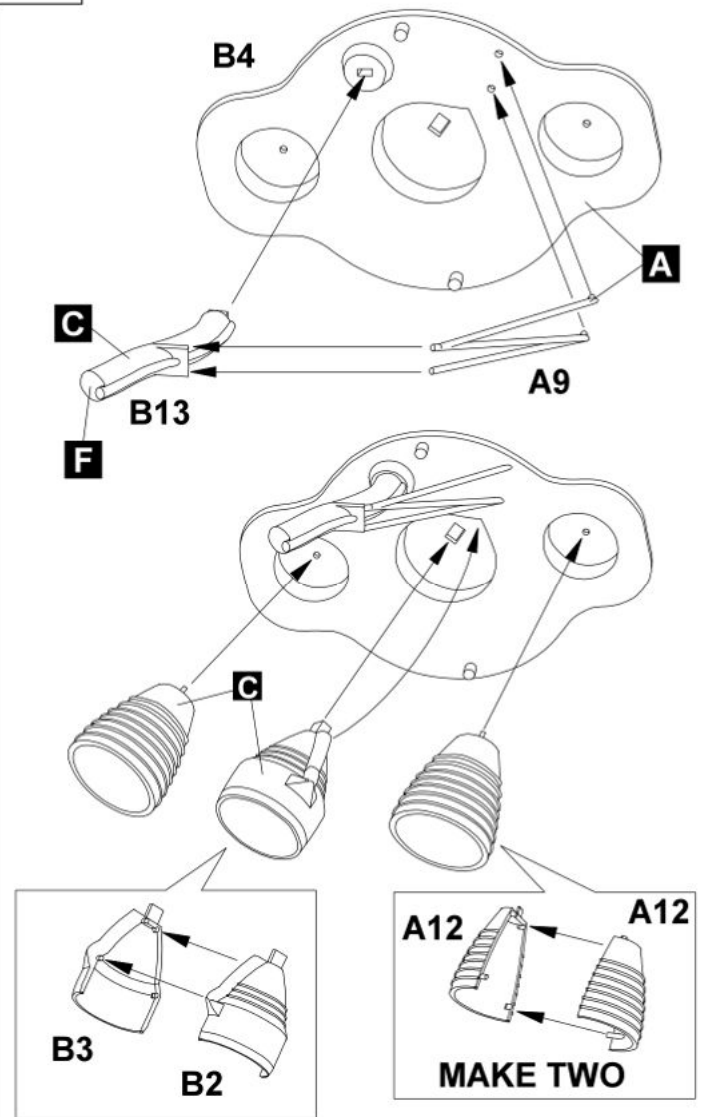

7 FINAL ASSEMBLY

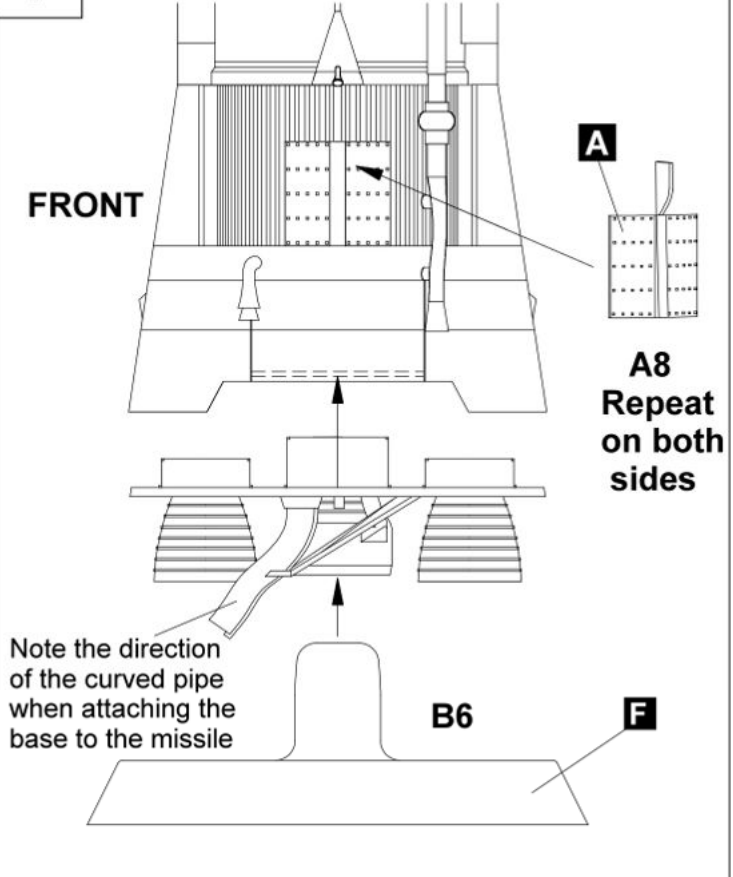
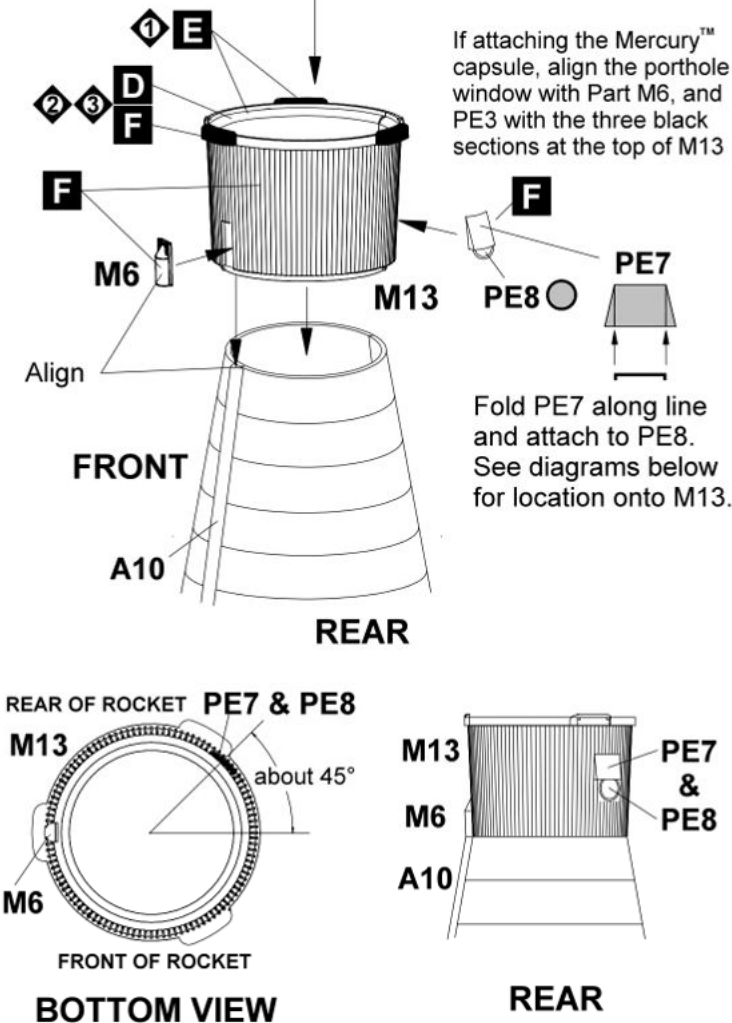

APPLY DECALS

*Repeat on other side

1

Mercury™ Boilerplate
"Big Joe" 10D

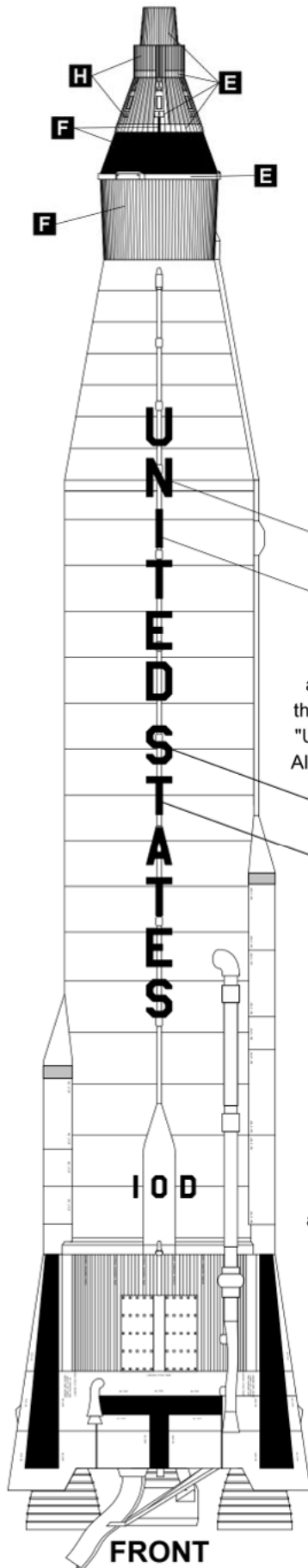

2

Mercury™ Capsule (Porthole)
Missions MA-1 to MA-4

- MA-1 50D
- MA-2 67D
- MA-3 100D
- MA-4 88D

For MA-1 only,
trim the tower
as shown.



40
UNITED STATES

9*

10

Use decals #10
and #12 over the
thin pipe in line with
"UNITED STATES"
Alternatively cut #13

12

11*

Use decals #38
and #39 over the
thin pipe in line
with the serial
number if
required.
Alternatively cut #37.

88D

REAR

3

Mercury™ Capsule (Window)
Missions MA-5 to MA-9

- MA-5 93D
- 45 MA-6 109D
- 46 MA-7 107D
- 47 MA-8 113D
- 48 MA-9 130D

Mission
Decals:

27
(x4)

Refer to step 4
for painting of
Mercury™
Spacecraft

1*

2

Use decals #2
and #4 over the
thin pipe in line with
"UNITED STATES"
(alternatively cut #5)

4

3*

Apply the relevant
serial number to
both sides of
the model for
the mission you
are modelling.

109D

41
(x2)

FRONT

30

MA-7 & MA-8:
bottom square only
MA-9: all three
white squares
Does not
appear on any
other mission.

40
UNITED STATES

41
UNITED STATES

Mission
logos decals
#45 to #48
underneath
window

41
(x2)

41
(x2)